



Safe remote valve operation for the shipbuilding, offshore, oil & gas and general industry

SafeOperator

The Solution in Remote Valve Drive Technology

Remote mechanical valve control for your industry

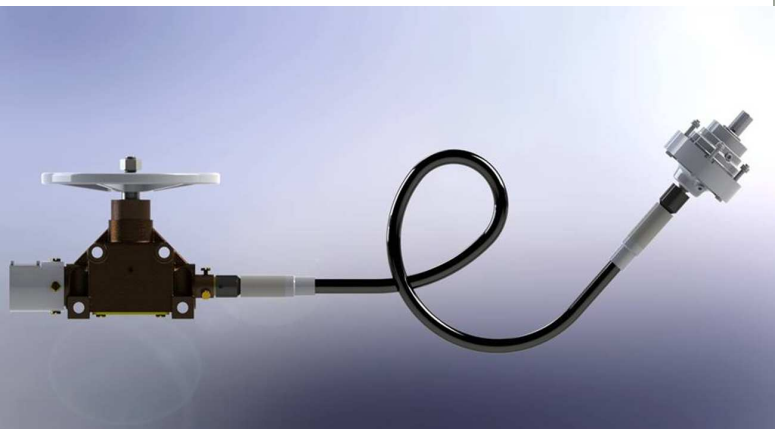



Welcome to *SafeOperator* - the safe and easy way to remotely operate valves

SafeOperator is the most comprehensive solution for the remote operation of valves, in every industry, available today. We lead the world in delivering systems which make your industry a safer place.

- Remote mechanical systems for the operation of valves allow every industry to locate the point of operation in a place of safety or convenience. *SafeOperator* allows you to improve safety with greater versatility.
- No exposed moving parts
- Operate valves in any location, even underwater.
- Very reliable with a minimum number of moving components
- Remote valve position indication
- Easy to plan and install with minimum engineering and no special tools required
- The simple alternative to a powered (electric, hydraulic, pneumatic) actuators.
- Safety and versatility with our complete and proven *SafeOperator* range.

The product range

The *SafeOperator* range features two system solutions :

Standard Flexible shaft (FS System)

- FS1—Flexible shaft system using our smaller shaft option. Combine with a gearbox to achieve higher torque output.
- FS2—Flexible shaft system using our larger shaft option. Combine with a gearbox to achieve higher torque output

Flexible shaft system with integrated gearing (IG System)

- IG1—Geared system using our smallest flexible shaft and compact gearbox
- IG2—Geared system using a larger flexible shaft and larger, but compact, gearbox

Valve data required

The following data is required to select the best system for your valve.

- Valve torque and/or valve handwheel size
- Routed distance from place of operation to the valve
- Number of turns to open/close the valve
- Valve type—Ball, Gate etc.
- Valve operation - rising handwheel, rising stem, non-rising stem
- Preferred connection to valve; existing handwheel or stem
- Type of remote operator you need and if you need valve position indication

You can download our datasheet from www.elliottsafeoperator.com.

Complete the datasheet and email to us. We will get back to you with a system proposal and quote.



Standard Flexible Shaft System— FS System

General Design Characteristics	System	Not Geared	
Maximum input torque	FS1	50 ft lbs	use gearing to increase output
	FS2	80 ft lbs	use gearing to increase output
Maximum system length (At valve torque =10ft lbs)	FS1	40 ft	
	FS2	80 ft	
Maximum degrees of bend (Approx.)	FS1	720	
	FS2	720	
Minimum bend radius	FS1	12 inches	
	FS2	18 inches	
Minimum length	Both	3ft	
Direction of operation	Both	Input/output same	
Maintenance	Both	Scheduled maintenance not required	
Operating environment	Both	-30°F to +350°F	

If needed, we will add a gearbox to achieve high system torques

Even the largest valves can be remotely operated!

Examples of FS system configurations

1. Panel mount handwheel with no valve position indicator. Connection to the valve is made with a valve handwheel coupling.
2. Panel mount handwheel with no valve position indicator. Connection to the valve is made directly to the valve stem. The FS coupling end is made to suit the valve stem diameter.
3. Remote operator with valve position indication. Connection to the stem of a gear box which can also be supplied with the system

These are examples . Other combinations are possible.

Please review the online calculator at www.elliotsafeoperator.com and then choose the system components for your remote valve installation.



WE ADD A GEARBOX TO CREATE A SYSTEM WHICH WILL HANDLE EVEN THE LARGEST VALVES.

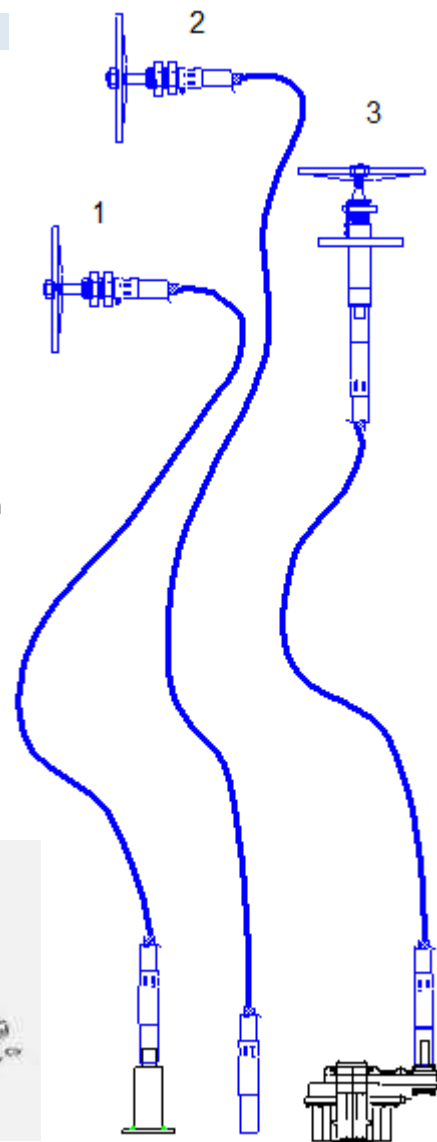

If needed, the gearbox can be connected directly to the valve using a coupling kit. These are engineered to suit your valve flange.



FS Installation options

Operators

Remote operating stations

Accessories

Valve connection options



Lever for 1/4 turn operation



Handwheel for multi-turn operation

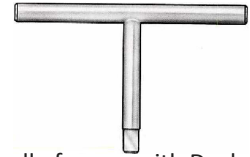

T Handle for use with Deck Box



Panel mount Flexible shaft assembly with valve position indication



Panel mount Flexible shaft assembly without valve position indication

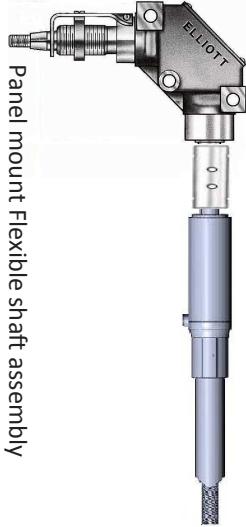

90° degree Remote Operator with valve position indication

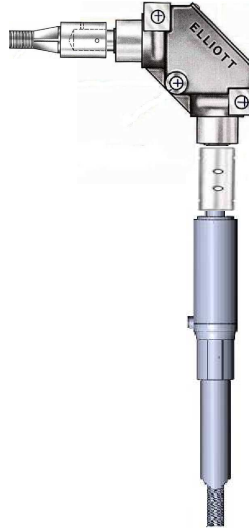

90° degree Remote Operator without valve position indication



Deck box remote operator

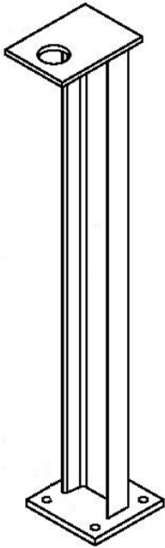

Floorstand for remote operating stations



Deck/Floor box allowing for watertight penetration of a deck or floor.



Clamp for securing the Flexible shaft assembly



Non-rising handwheel valve



Rising handwheel valve



Rising stem valve



Direct fit to valve input shaft

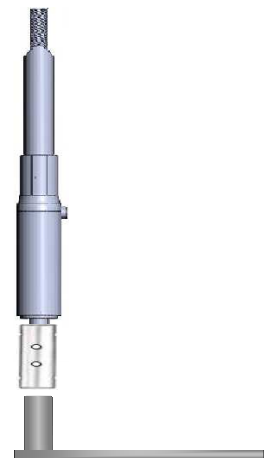

Lever type valve



Flexible Shaft Assembly

Elliott Flexible Shaft Assemblies are designed for manual, slow speed operation or intermittent power drive applications. Each assembly is constructed with Elliott's high strength steel inner core for minimum torsional deflection in either direction, and is encased in tough, water-tight casing. The operator end of the assembly may be connected by a simple lock nut arrangement to make a panel mount. An adapter can be added to allow handwheel connection. The output end of the assembly is a male round to which a variety of adapter ends are added.

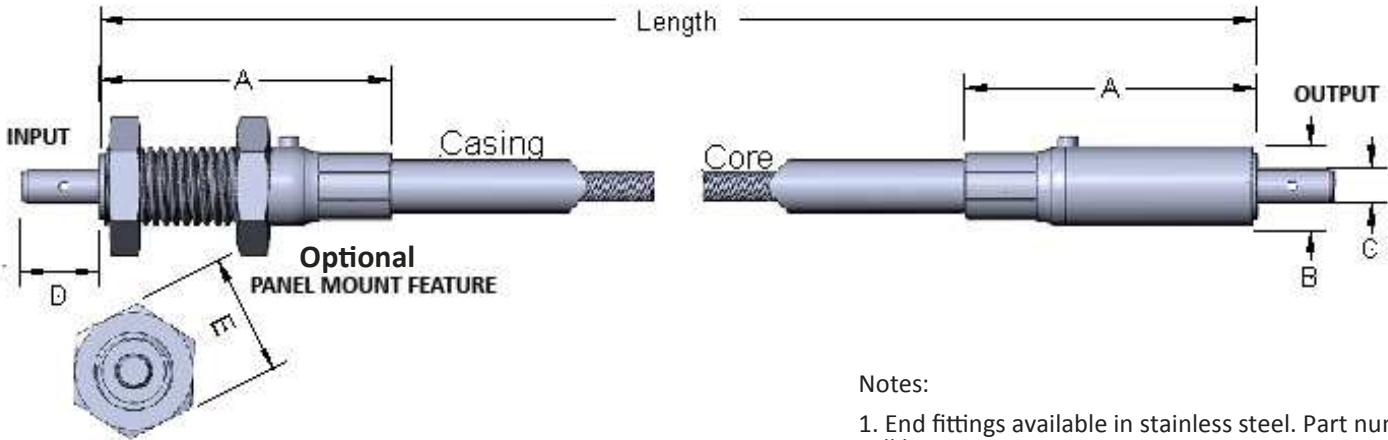

Notes:

1. End fittings available in stainless steel. Part number will be 12180-203-XXX or 12180-204-XXX
2. XXX= Length in inches
3. If panel mount required add PM as suffix

Type	ELLIOTT Part No.	Core Dia.	Casing Dia.	A	B	C	D	E
FS1	12180-103-XXX	5/8	1.00	5.00	1 3/8	23/32	1.00	2.00
FS2	12180-104-XXX	1	1 9/16	6.00	2.00	1.00	1 1/8	3.00

Flexible shaft support

The rotary flexible shaft assembly (inner core and casing) is supported by clamps which are bolted or tack welded to the rigid structures. Clamps secure the rotary flexible shafting as close to remote operator and valve as possible. Clamps are used throughout the rotary flexible shafting run at approximately five foot intervals where convenient. Where radial bends are installed in the rotary flexible shafting run, they are to be made as large as possible to minimize frictional loading. Clamps are to be located at the beginning and end of a radial bend as a minimum, also in the middle of the bend, if possible. The casing that supports the core during operation is manufactured from carefully chosen material to withstand the effects of dust, oil, moisture, abrasion and temperature extremes.

Standard end adapter



Standard adapters are required to connect the Flexible Shaft Assembly to input and output mating parts, such as a 90 degree Operator, Deck Box or Valve Handwheel Coupling. Non-standard bore sizes are available to suit most valve input shaft diameters. Pins supplied with adapters.

Elliott Part No.	Used on	Output bore size
12668-101	12180-103	0.62
12668-102	12180-103	0.75
12668-103	12180-104	0.75
12668-104	12180-104	1.00
12668-105	12180-104	1.25

Flexible shaft clamp



Elliott Part No.	Used on
20332-3	12180-103-XXX
20332-4	12180-104-XXX

Deck penetration (stuffing box)



Allows watertight penetration of a deck or floor/wall

Elliott Part No.	Used on
20331-402	12180-103-XXX
20331-403	12180-104-XXX

Values shown in above charts and graphs are in Inches



Remote Operator with position indication and Floor Stand

The Elliott Remote Operator end fitting serves as a termination point for Flexible Shaft Assemblies when valve position indication is required. The unit, when fitted to a Flexible Shaft Assembly, is designed to surface mount through a floor or wall using the locking nuts of the Flexible Shaft Assembly. This unit, and non-indication Flexible Shaft Assemblies, can also be mounted on fabricated floor stands. The units accommodate all handwheel sizes (6" and above) and indicate up to a maximum of 100 turns to open and close. Indicator parts are fabricated from noncorrosive materials and are suitable for use in any number of hostile environments.

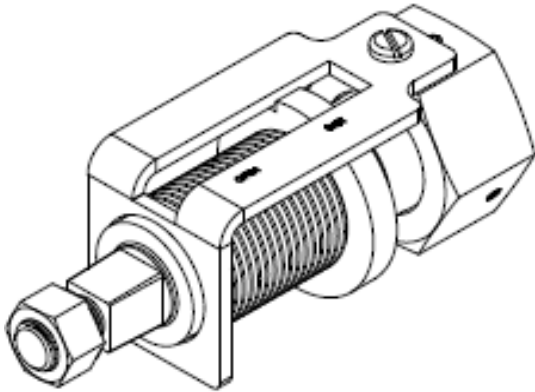

Part 20261 for valve position indication

Part No.	Fit		Hand-wheel	Usable Turns
	FS type	SQ	SQ	
20261-101	1	0.75	0.75	25
20261-102	1	0.75	0.75	50
20261-103	1	0.75	0.75	100
20261-104	2	1.19	1.19	25
20261-105	2	1.19	1.19	50
20261-106	2	1.19	1.19	100

FS1 or 2 without valve position indication and fitted with a handwheel adapter.



FS1 or 2 with valve position indication

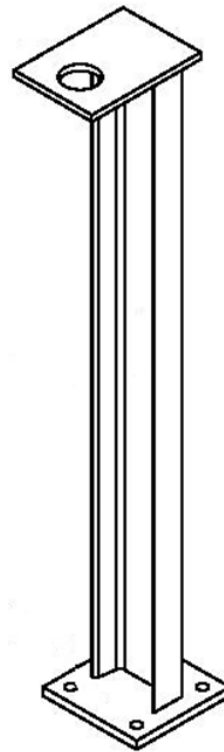

Part 20360

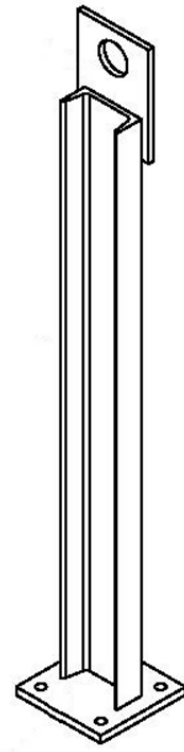

Part 20380

Part No.	Fits	
	FS type	
20360-101-034	1	
20360-102-034	2	
20380-101-034	1	
20380-102-034	2	

Note: Floor stand height to suit customer requirements. If alternate height is required change the part number suffix to height in inches.

Values shown in above charts and graphs are in Inches



90° Gear Box Operator with and without valve position Indication

The Elliott 90° Gear Box with Indication is ideal for both controlling valves from remote locations and providing indication at the same time. These units are especially convenient for mounting on walls, bulkheads or other vertical surfaces. The units are furnished as a standard item with a choice of either bronze or aluminum housings. The units will indicate from 11 to 34 turns to open (maximum) depending on the size selected. The unit comes pre-lubricated at the factory and is totally sealed and watertight.

With valve position indication

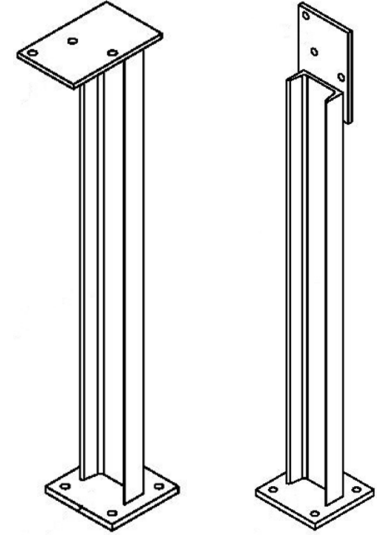
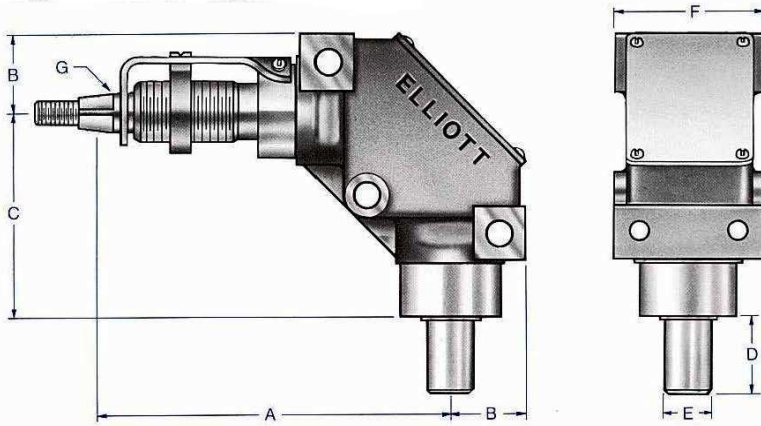

Part No.	A	B	C	D	E	F	G	Usable Turns
20453-701	7.41	1.62	4.38	1.50	0.75	3.00	0.75	14
20453-703	8.08	1.62	4.38	1.50	1.00	3.00	1.19	34

Part No.	Fits FS type
20360-103-034	1&2
20380-103-034	1&2

Without valve position indication: combine with a handwheel adapter to allow handwheel attachment

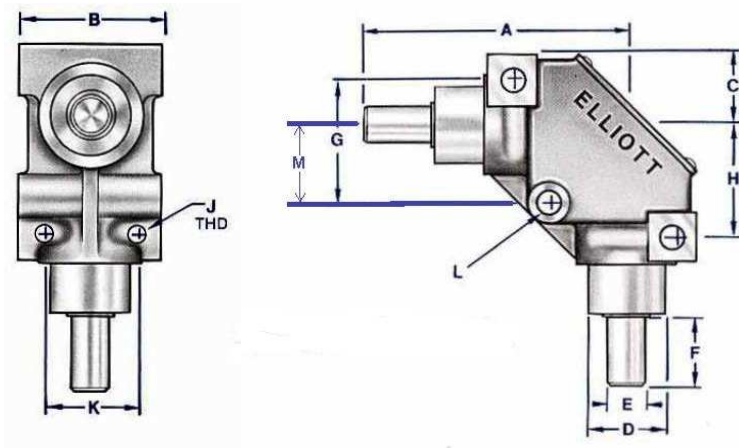

Note: Floor stand height to suit customer requirements. If alternate height is required change the part number suffix to height in inches.

Part No.	A	B	C	D	E	F	G	H	J THD	K	L	M
20409-701	5.94	3.00	1.63	2.25	0.75	1.50	2.75	2.63	1/2-13	2.00	0.56	1.75
20409-703	5.94	3.00	1.63	2.25	1.00	1.50	2.75	2.63	1/2-13	2.00	0.56	1.75

Values shown in above charts and graphs are in Inches



Deck box

The Deck Box is designed for precise remote control during partial or full operation of a remote valve. Its indicator reveals at a glance the exact operating position of the valve. It is recommended for installation which might need; 1) to save space at the operating position—the deck box is often install flush to a deck/floor; 2) group a number of operators together in one central operating panel; 3) a degree of protection against tampering. The indicator show 100 or 40 turns for multi-turn valves and 360° for one turn or less; typically 1/4 turn valves without gearing.

Deck box will indicate valve turns for either 1/4 turn operation—360° type—or multi turn valve operation— 40 or 100 turns.

Deck box are supplied with a weld sleeve. Request part 12188 if you require a bolt flange

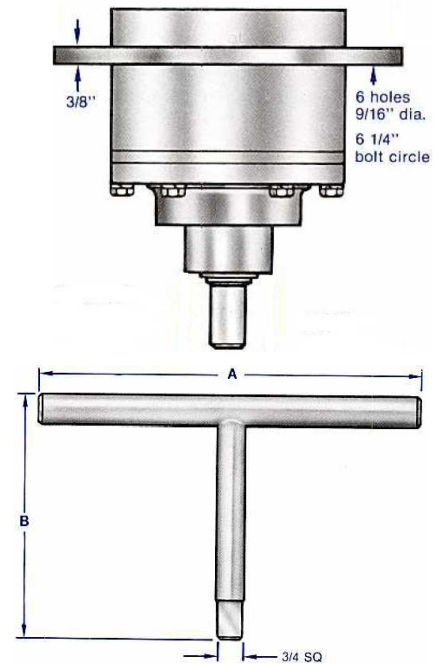
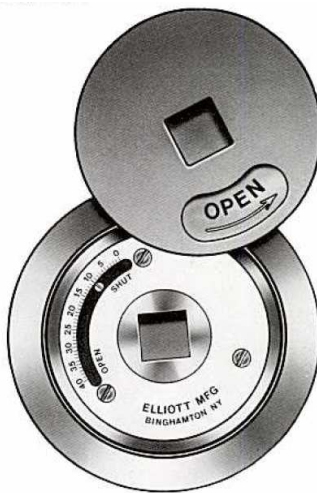
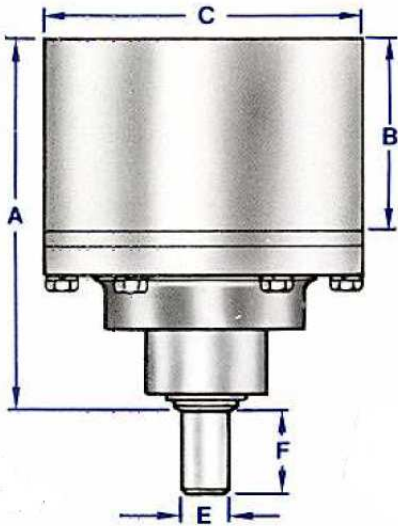

Part No.	No. of turns	A	B	C	D	E	F
20404-503	40	5.72	3.12	4.88	2.25	1.00	1.50
20454-503	360°	5.72	3.12	4.88	2.25	1.00	1.50
20461-503	100	5.72	3.12	4.88	2.25	1.00	1.50

Elliott Number	A	B
12144-3	12	15.31
12144-4	20	12.31

Values shown in above charts and graphs are in Inches



Hand Wheels also available in bronze

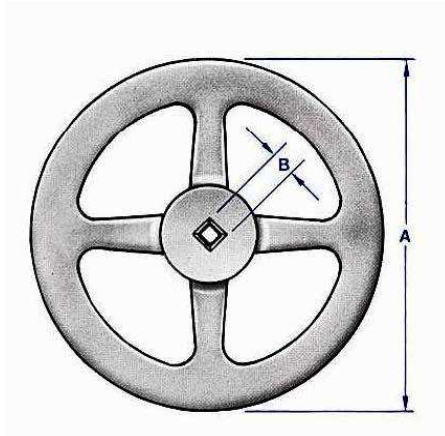

Aluminum	With quick turn handle	A	B SQ
12142-612	12951-612	6.00	0.75
12142-621	12951-621	8.00	0.75
12142-629	12951-629	10.00	0.75
12142-630	12951-630	10.00	1.19
12142-633	12951-633	12.00	0.75
12142-635	12951-635	12.00	1.19
12142-637	12951-637	14.00	0.75
12142-639	12951-639	14.00	1.19
12142-641	12951-641	16.00	1.19
12142-643	12951-643	18.00	1.19
12142-646	12951-646	21.00	1.19
12142-650	12951-650	27.00	1.19

Lever

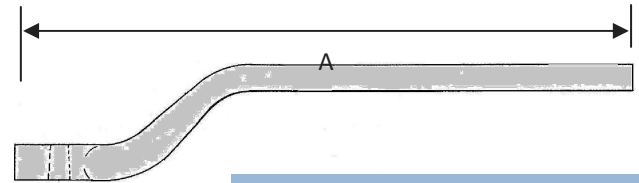

Part No.	A LGTH	SQ
S23085-357	8.00	0.75
S23085-352	12.00	0.75
S23085-354	16.00	0.75
S23085-356	20.00	0.75
S23085-364	8.00	1.19
S23085-359	12.00	1.19
S23085-361	16.00	1.19
S23085-363	20.00	1.19

Handwheel Adapters

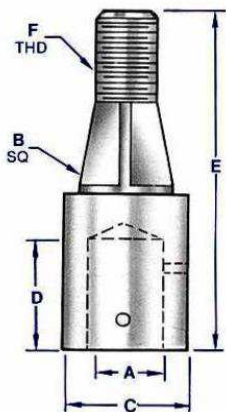

ELLIOTT Part No.	A DIA	B SQ	C DIA	D	E	F THD
20443-107	0.75	0.75	1.25	1.12	3.38	5/8-11
20443-108	1.00	0.75	1.50	1.50	3.81	5/8-11
20443-110	1.00	1.19	1.75	1.50	5.06	1-8
20443-124	0.72	0.75	1.25	1.12	3.38	5/8-11

Hex Nut for fixing handwheel supplied with handwheel adapter

Values shown in above charts and graphs are in Inches



Valve Handwheel Couplings

Elliott manufactures a complete line of Valve Couplings that are suitable for use on non-rising handwheel valves, rising stem valves and rising handwheel valves. The units are fabricated from carbon steel and are available in a range of sizes to fit handwheels with diameters ranging from 3 inches to 30 inches. The units are attached to existing valve handwheels with U-Bolts (supplied by installer) so that assembly and disassembly can be accomplished quickly and easily. **No modification to the existing valve is required.**

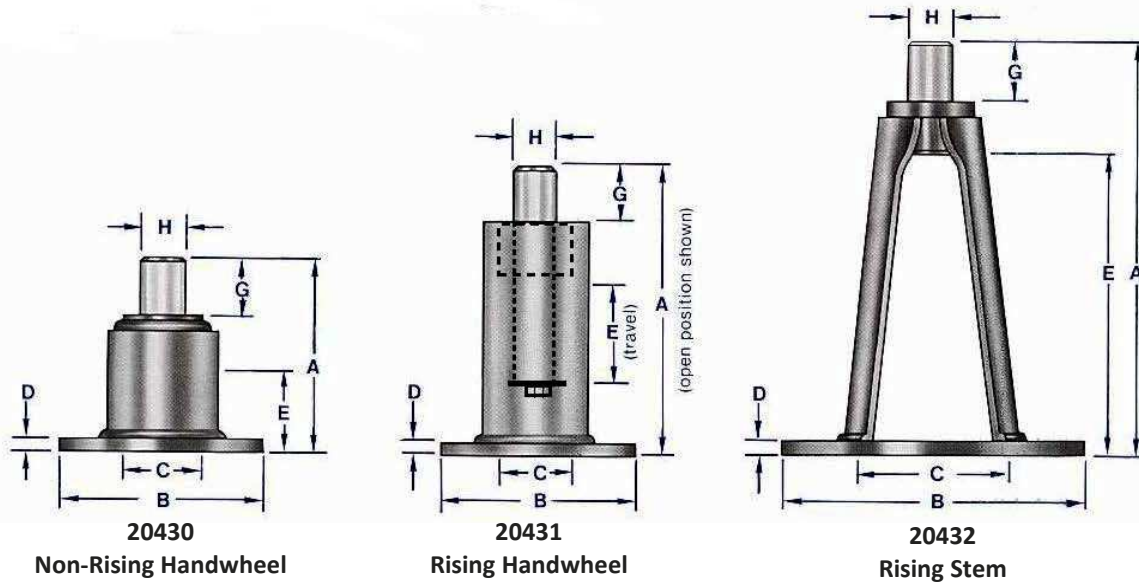

Select the best fit to handwheel diameter and/or stem stroke

ELLIOTT Part No.	A	B	C	D	E	G	H
20430-510	3.19	3.25	1.25	0.19	1.38	0.94	0.62
20430-501	3.38	4.25	1.62	0.19	1.38	1.12	0.75
20430-503	3.75	6.50	2.00	0.25	1.38	1.50	1.00
20430-505	4.44	8.00	2.38	0.31	1.56	1.88	1.25
20431-510	4.94	3.25	1.25	0.19	1.50	0.94	0.62
20431-501	6.62	4.25	1.62	0.19	2.75	1.12	0.75
20431-503	8.88	6.50	2.00	0.25	4.25	1.50	1.00
20431-505	11.75	8.00	2.38	0.31	6.00	1.88	1.25
20432-510	6.81	4.75	2.38	0.25	5.00	0.94	0.62
20432-501	9.38	5.50	3.00	0.25	7.38	1.12	0.75
20432-503	13.75	7.00	3.88	0.25	11.38	1.50	1.00
20432-505	20.12	8.75	4.88	0.31	17.25	1.88	1.25



Easy connection to valve handwheel

Valve handwheel coupling flange is drilled at installation for attachment to valve handwheel using U-bolts or other suitable bolts.

Lever coupling bolted to existing valve lever

Drilling and bolts supplied by the installer.

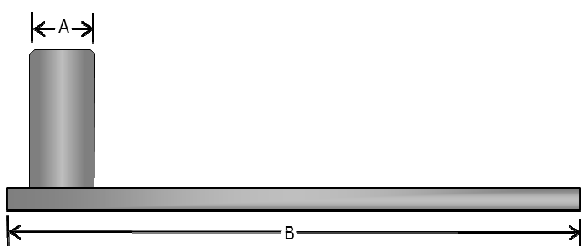

Lever coupling

ELLIOTT Part No.	A	B
20350-101	0.75	10.00
20350-102	1.00	14.00

Values shown in above charts and graphs are in Inches



Geared Flexible Shaft System— IG System

General Design Characteristics	System	
Maximum valve torque	IG1	53 ft lbs
	IG2	250 ft lbs
Maximum system length (At valve torque = 10ft lbs)	IG1	100 ft
	IG2	125 ft
Maximum degrees of bend (approx.)	IG1	720
	IG2	720
Minimum bend radius	IG1	8 inches
	IG2	10 inches
Minimum system length	Both	5ft
Direction of operation	Both	Input/output same
Maintenance	Both	Scheduled maintenance not required
Operating environment	Both	-30°F to +350°F

Examples of IG systems configurations

1. Remote operator with valve position indication. Gearbox at the valve is rigid mounted on separate structure. A valve handwheel coupling allows easy connection to the valve and the offset between the valve and the valve gearbox is taken up using a double universal joint.
2. Remote operator with valve position indication. Gearbox at the valve is rigid mounted on separate structure. A double universal joint, with output bore to suit the valve stem, is connected directly to the valve stem.
3. Remote operator with valve position indication. Gearbox at the valve is rigid mounted directly to the valve using a valve adapter kit. Kits are made to order.

These are examples . Other combinations are possible.

Typical system configuration

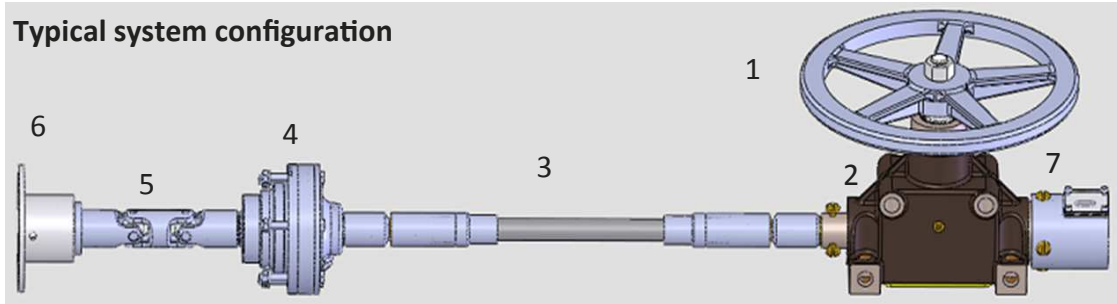

If needed, the gearbox can be connected directly to the valve using a coupling kit.

These are engineered to suit your valve flange.

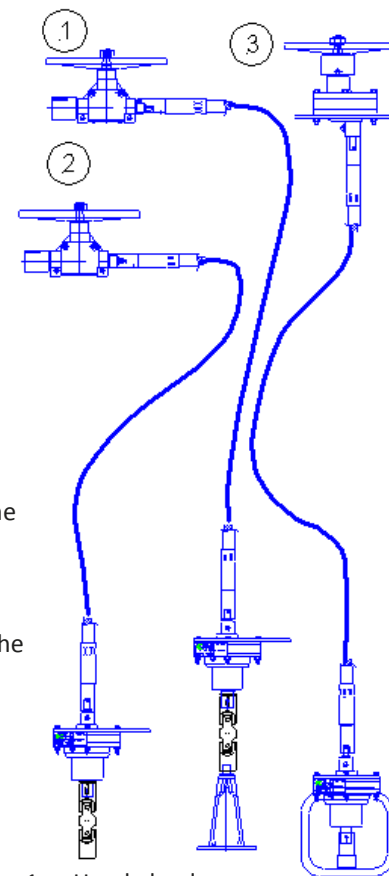

1. Handwheel
2. Remote operator
3. Flexible shaft
4. Valve gearbox
5. Universal Joint
6. Valve Handwheel Coupling
7. Valve position indication



Remote Operators with valve position indication

The Elliott remote operating stations serve as an operation point for the IG system. These units are designed to surface mount and can also be mounted on a fabricated structure to serve as a floor stand. The counter type indicator can indicate 0-9,999 turns and can easily be replaced if damaged without removing the operator assembly. These units accommodate handwheels up to 16 inches in diameter with a .75" tapered square. The deck box uses a T handle.

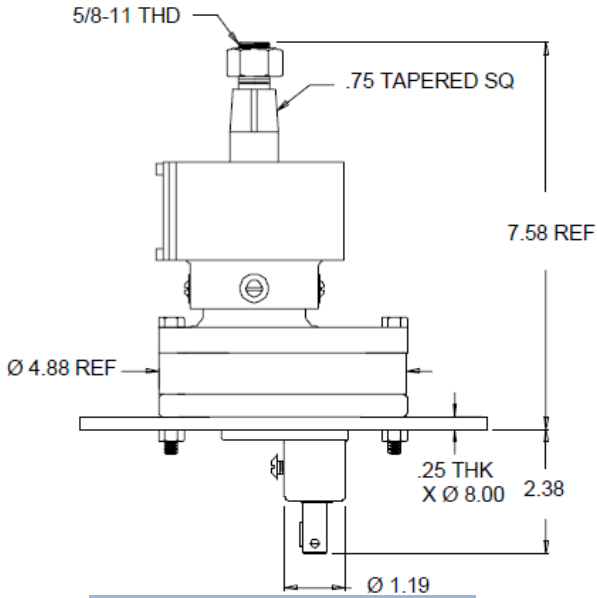
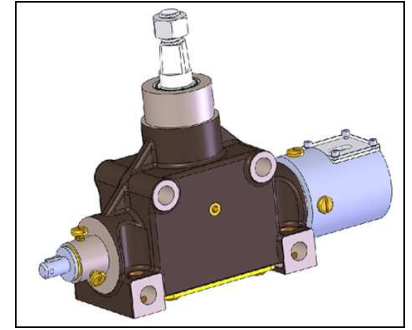

Part	Type
22100M180A	Bolt Flange
22101M180A	Weld Flange

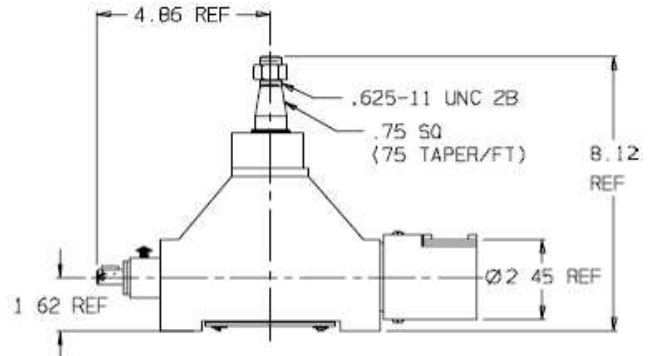

Part	Type
22299	90 degree

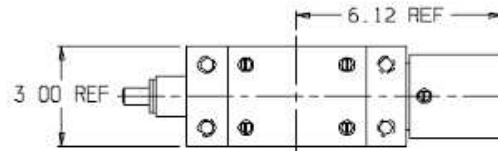

The Deck Box is designed for precise remote control during partial or full operation of a remote valve. Its indicator reveals at a glance the exact operating position of the valve. It is recommended for installations which may need; 1) to save space at the operating position—the deck box is often install flush to a deck/floor; 2) group a number of operators together in one central operating panel; 3) a degree of protection against tampering.

See Page x for details of the optional bolting flange and T handle.

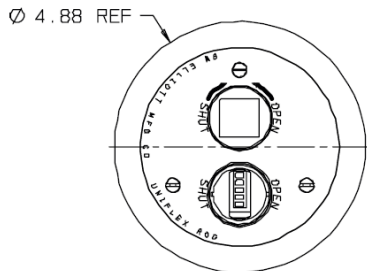
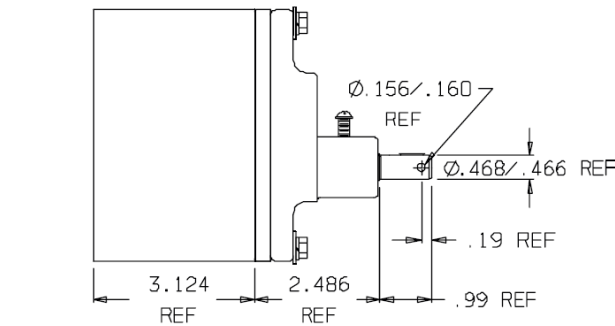

Part	Type
22073-100	Deck box

Values shown in above charts and graphs are in Inches



Hand Wheels also available in bronze

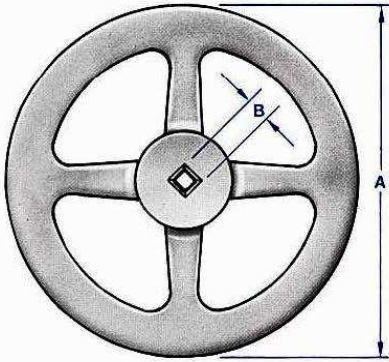

Aluminum	With quick turn handle	A	B SQ
12142-612	12951-612	6.00	0.75
12142-621	12951-621	8.00	0.75
12142-629	12951-629	10.00	0.75
12142-633	12951-633	12.00	0.75
12142-637	12951-637	14.00	0.75
12142-655	12951-655	16.00	0.75

Floor Stands

Note: Floor stand height can be to suit customer requirements. If alternate height is required change the part number suffix to height in inches.

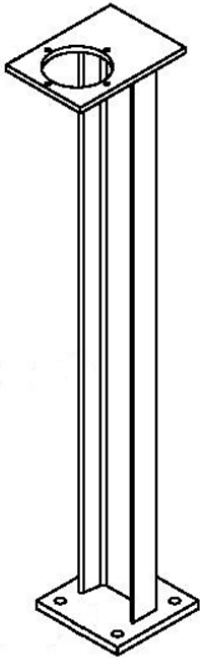

Part 20360 -105-034
Horizontal operation
22100M180A

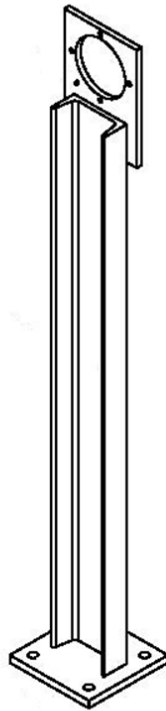

Part 20380 -105-034
Vertical operation
22100M180A

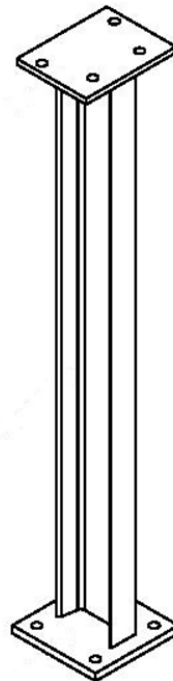

Part 20360 -104-034
Horizontal operation
22299

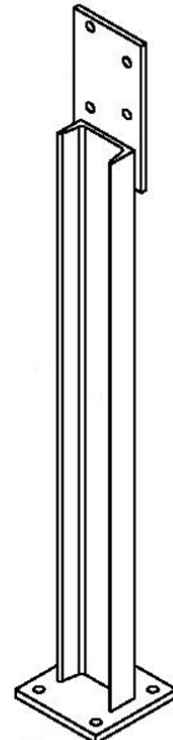

Part 20380 -104-034
Vertical operation
22299

Values shown in above charts and graphs are in Inches



Flexible shaft drive assembly

High quality flexible drives deliver torque with the maximum efficiency. There are two options in the range IG1 (3/8" flexible shaft) and IG2 (1/2" flexible shaft). Both shafts are enclosed in a hard wearing hytel covered flexible casing. They use simple push-on connectors, secured with set screws, to the valve gearbox input shaft and remote operator output shaft.

Simple assembly - Easy Installation



Type	Part No.	A	B
IG1	12468-101-XXX	5.03	1.12
IG2	12472-101-XXX	6.78	1.25

XXX = length in inches

End fittings available in stainless steel. Part number will be 12180-203-XXX or 12180-204-XXX

Flexible shaft clamp



Part No.	Used on
20332-1	12468-101-XXX
20332-2	12472-101-XXX

Flexible shaft support

The rotary flexible shaft assembly (inner core and casing) is supported by clamps and mounting brackets which are bolted or tack welded to the rigid structures. Clamps secure the rotary flexible shafting as close to remote operator and valve as possible. Clamps are used throughout the rotary flexible shafting run at approximately five foot intervals where convenient. Where radial bends are installed in the rotary flexible shafting run, they are to be made as large as possible to minimize frictional loading. Clamps are to be located at the beginning and end of a radial bend as a minimum, also in the middle of the bend, if possible. The casing that supports

Double Universal Joint

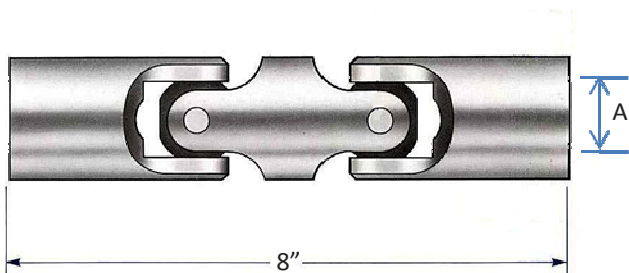

Part No.	A Output bore size	Used With
12663-201	0.75	IG1
12663-202	0.625	IG1
12663-203	0.75	IG2
12663-204	1.00	IG2
12663-205	1.25	IG2

Output bore size 'A' can be to customer requirements if fitting directly to valve or valve gearbox input shaft.

Deck penetration (stuffing box)



Allows watertight penetration of a deck or floor/wall

Part No.	Used on
20331-400	12468-101-XXX
20331-401	12472-101-XXX



Valve Gearbox

This unique epicycloidal design has advantages superior to other gearboxes using common involuted tooth gears. Components operate in compression, not in shear. Unlike gear teeth with limited contact points, it has two-thirds of its reduction components in contact at all times. This design enables the gearbox to withstand shock loads exceeding 500% of their ratings, and provide exceptional performance, reliability and long life in the most severe applications.

System	Nominal System							
	Ratio →	2:1	3:1	4:1	6:1	9:1	15:1	21:1
IG 1	Valve gearbox	12464-6	12464-8	12464-11	12464-17	12464-25	12464-43	12464-59
IG 2	Valve gearbox	12463-6	12463-8	12463-11	12463-17	12463-25	12463-43	12463-59

When a mounting plate is required order; 12662-1 with 12464 ; 22010-3 with 12463

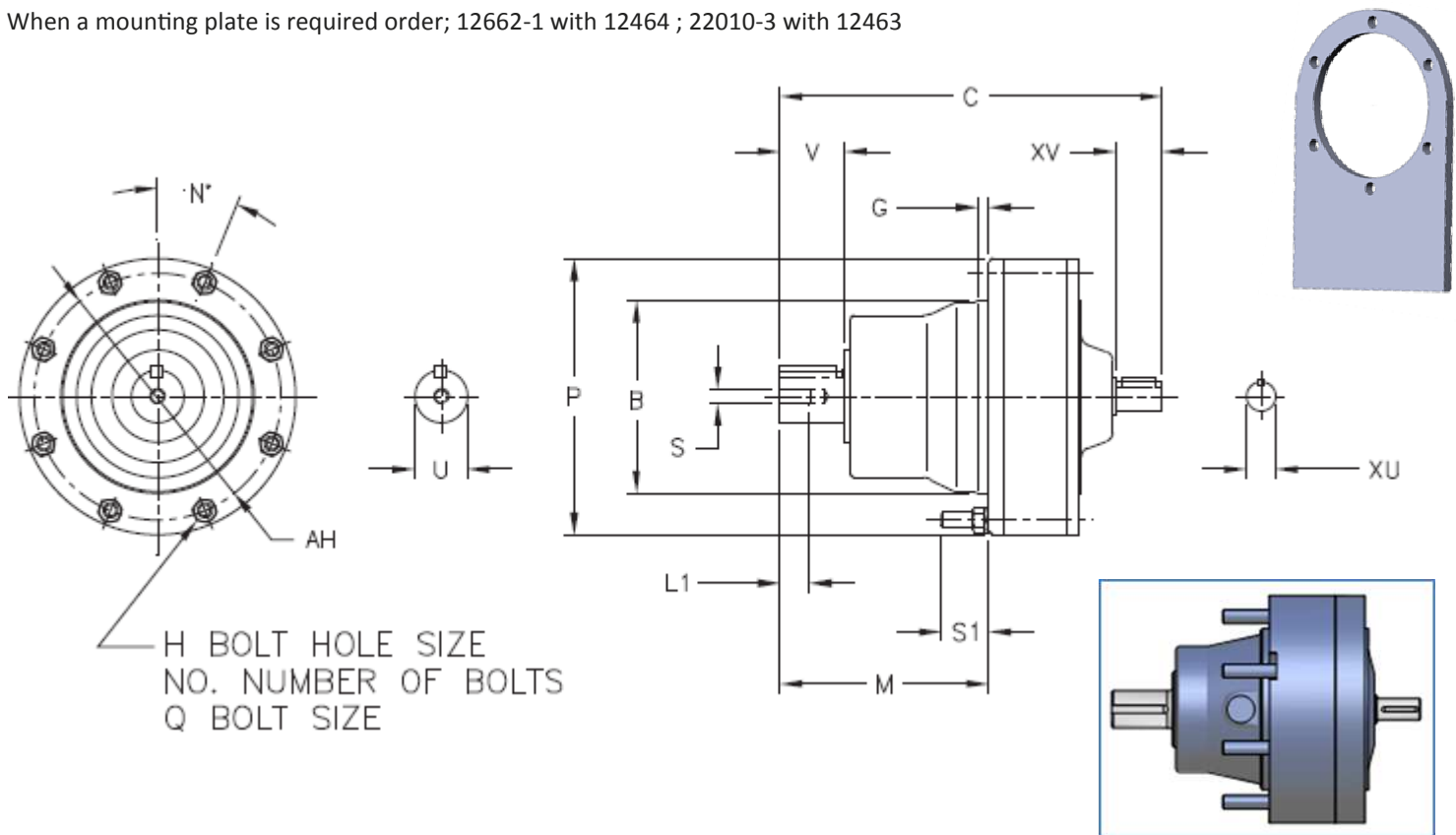

Dimensions	B	C	G	H	no.	M	N	P	Q	S1	AH	APPROX. WEIGHT (LBS)
12464	3.1492 3.1485	5.94	0.16	0.26	6	2.91	60	4.33	M6	0.83	3.86	
12463	4.1334 4.1325	7.95	0.24	0.35	8	4.49	22.5	5.91	M8	1.14	5.28	
	U	V	S	L1	OUTPUT KEY	XU	XV	INPUT KEY				
12464	0.75	1.18	12-28UNF	0.63	3/16X3/16X1.06	0.5	0.98	1/8X1/8X0.71				7
12463	1.125	1.38	5/16-18UNC	0.79	1/4X1/4X1.18	0.625	0.98	3/16X3/16X.75				19

Values shown in above charts and graphs are in Inches



Valve Handwheel Couplings

Elliott manufactures a complete line of Valve Couplings that are suitable for use on non-rising handwheel valves, rising stem valves and rising handwheel valves. The units are fabricated from carbon steel and are available in a range of sizes to fit handwheels with diameters ranging from 3 inches to 30 inches. The units are attached to existing valve handwheels with U-Bolts (supplied by installer) so that assembly and disassembly can be accomplished quickly and easily. **No modification to the existing valve is required.**

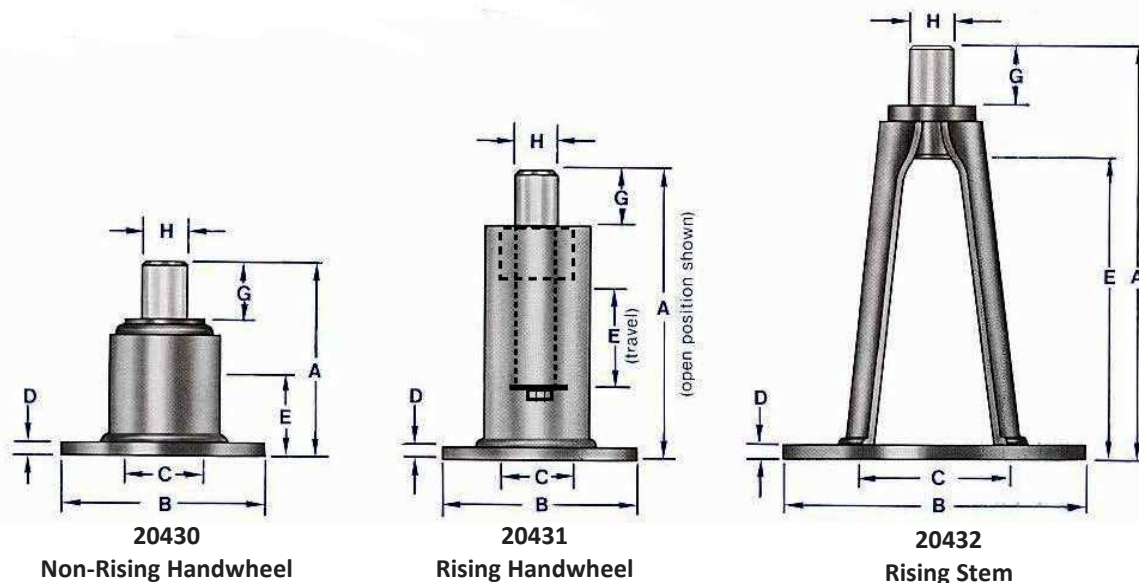

Select the best fit to handwheel diameter and/or valve stem stroke

ELLIOTT Part No.	A	B	C	D	E	G	H
20430-510	3.19	3.25	1.25	0.19	1.38	0.94	0.62
20430-501	3.38	4.25	1.62	0.19	1.38	1.12	0.75
20430-503	3.75	6.50	2.00	0.25	1.38	1.50	1.00
20430-505	4.44	8.00	2.38	0.31	1.56	1.88	1.25
20431-510	4.94	3.25	1.25	0.19	1.50	0.94	0.62
20431-501	6.62	4.25	1.62	0.19	2.75	1.12	0.75
20431-503	8.88	6.50	2.00	0.25	4.25	1.50	1.00
20431-505	11.75	8.00	2.38	0.31	6.00	1.88	1.25
20432-510	6.81	4.75	2.38	0.25	5.00	0.94	0.62
20432-501	9.38	5.50	3.00	0.25	7.38	1.12	0.75
20432-503	13.75	7.00	3.88	0.25	11.38	1.50	1.00
20432-505	20.12	8.75	4.88	0.31	17.25	1.88	1.25

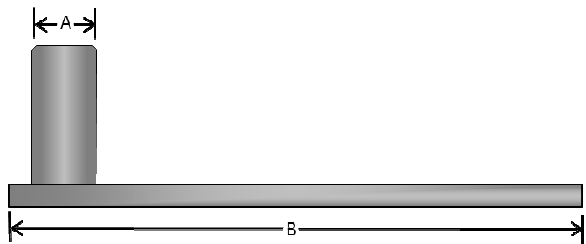

Lever coupling

ELLIOTT Part No.	A	B
20350-101	0.75	10.00
20350-102	1.00	14.00



Easy connection to valve handwheel

Valve handwheel coupling flange is drilled at installation for attachment to valve handwheel using U-bolts or other suitable bolts.

Lever coupling bolted to existing valve lever

Drilling and bolts supplied by the installer.

Values shown in above charts and graphs are in Inches



Collect as much information as possible and email to our technical team or go online @ www.elliotsafeoperator.com and use our system calculator to select your FS or IG system.

Customer	
Address	
Contact name	
Job title	
Email	
Telephone	

System information – please supply as much as you can

Valve data

Type	Handwheel operation	Handwheel type	Select	Size
Ball	Rising Handwheel	Handwheel		
Plug	Rising stem	Lever		
Butterfly	Non-rising handwheel			
Gate				
Globe				
Other				

Valve size:..... Valve Manufacturer and model (if known).....

Valve rating :.....

Gearbox fitted? Yes/No

If Yes; Gearbox ratio..... Gearbox MA.....

Maximum Input torque required to operate valve or valve gearbox.....

Total number of turns to open/close:..... valve only / valve with gearbox (delete one)

Routing

Routed distance from valve to point of operation.....

Estimated total degrees of bend.....

Number of 90 degree bends.....

Connect drive to handwheel or direct to valve stem?.....

Remote operator

Preferred handwheel position: vertical / horizontal to the floor

Is valve position indication required : Yes/No



Notes



Rev 3, December 2015

Elliott's **SafeOperator** and **Uniflex-stow**™ range is the most versatile, reliable and proven approach to remote mechanical valve actuation available today. It is a unique answer to the problem of remote mechanical valve actuation. When a valve is in a hazardous or hard-to-reach position, and must be actuated, then we solve the problem. It is the safe and reliable way to actuate almost any valve. If you are still specifying or using out-of-date chains, dual cable systems, linear systems or make-shift solid rod and UJ systems then think **SafeOperator** and **Uniflex-Stow**™- proven, reliable, virtually no maintenance and easy to plan and install.

In Nuclear, Marine & Naval and General Industry we drive to lead.

The Stow brand has been solving remote mechanical control problems for over 100 years. Elliott Manufacturing has combined this experience with new product development to deliver "The Solution in Remote Technology". **SafeOperator** for Shipbuilding and on and off-shore industries using valves. **Uniflex-stow** for Naval, Nuclear and special purpose situations. Request our catalog for more details.



B.W.Elliott Manufacturing Co.LLC

11 Beckwith Avenue

Binghamton

New York 13901

USA

Telephone: +1 607 772 0404

Email: uniflexstow@elliottmfg.com